

Fence Picket Stool

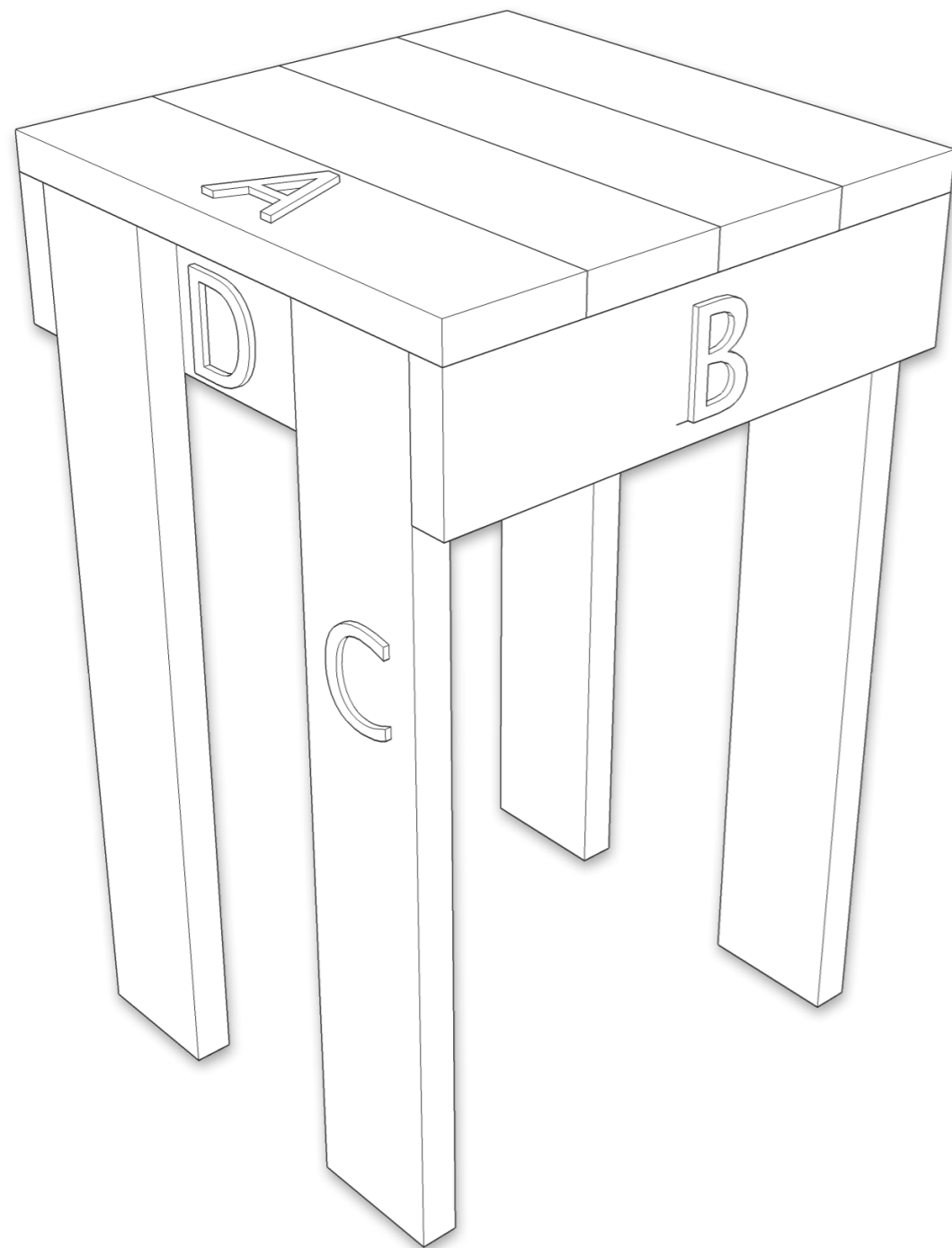

About this project

It is a simple one - nothing too challenging and you should knock it off in an hour or two.

What I am looking to get across to you is the basics of how furniture is constructed and a few tips and tricks to help. The design is nothing new and you will see it all over the place once you start looking.

There is a very good chance it will end up in your garden with a pot plant sitting on it but it will give you the basics of how to build a stool which is also the basics of how to build a table and a chair... and a book case... and you get where I'm going with this.

I've simplified the plan and construction down so that it can be made with very basic and cheap tools and materials that can easily be salvaged from the side of the road. Beginners start at the beginning.

AGLM Basic Stool by A Good Looking Man is licensed under a Creative Commons Attribution-Non-Commercial-ShareAlike 3.0 Unported License.

Safety

Having fingers is a wonderful thing. Losing one will probably put you off finishing your stool so please be careful - wear safety glasses and if something hurts then stop doing it.

Materials

Fence pickets usually come in two sizes (90mm wide x 18mm thick or 68mm x 18mm thick) and there are always loads of them about during verge side collection season. Go have a poke down some alleyways and in friends sheds. You will find some I'm sure. Nab as many as you can.

The design on the left uses the 68mm wide ones but you can adjust it to suit the 90mm wide ones.

You will also need a piece of MDF or Ply about 500mm long by about 150mm wide and 18mm thick - most hardware shops will carry something like this and can cut it to size for you for a dollar or two.

Shopping List

Read through the plan and call your pops before you go shopping - you may already have the scrap wood for the jig and the tools in the shed. Buy local as well if possible - support your neighbours!

What you will need

A hand saw

Drill bits - a 3mm pilot hole bit, a phillips head driver bit and if you can get one a countersink bit.

A drill - two if you can

Some screws - at least 22 x 32mm phillips head size 8 screws and 8 x 40mm screws size 8 phillips head

A stash of fence pickets - say 6 - 10 should do it

A claw hammer to remove the old nails in the pickets

A ~500mm x ~150mm piece of ply or MDF which is at least 18mm thick

A piece of ~70mm wide x ~500mm long @ ~18mm or greater thick timber.

A ruler/tape measure - preferably a metal one where the numbers go to the ends

A square

A clamp or two or a pal to help.

What would be handy

Saw horses - you can pick them up cheap and they are handy.

Sandpaper/paint/varnish if you want to get fancy and finish it up.

Clamps x2

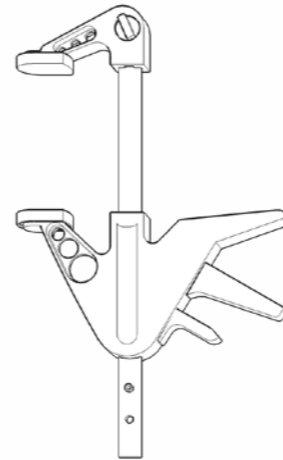

Saw x1



Screw x22 @ 32mm



Screw x8 @ 40mm



Drill/s, a 3mm pilot hole bit and a phillips head bit

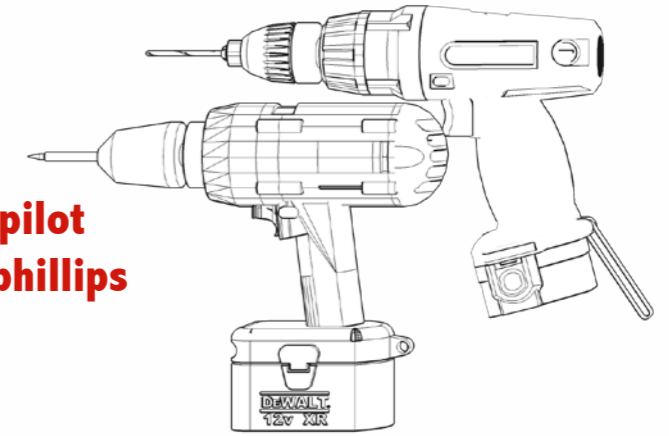

A set square

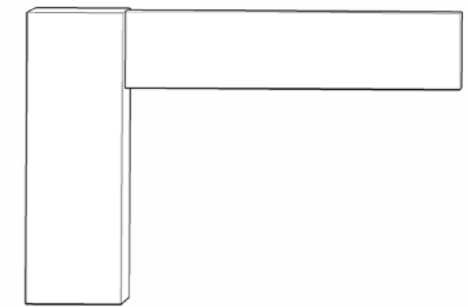

A tape measure

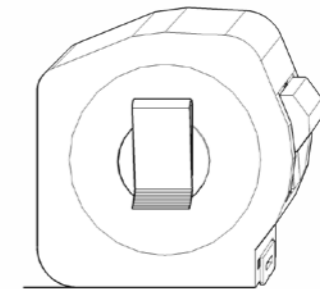

A hammer

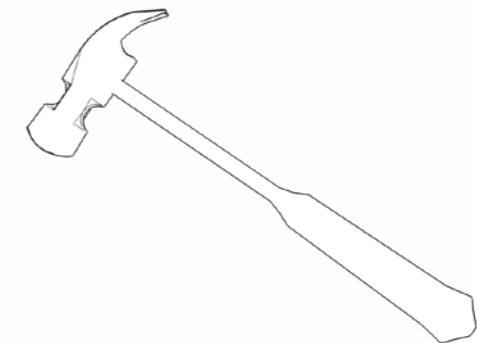

Shopping List

What you will need - explanations and advice

A hand saw- the larger toothed the better (and quicker to cut with). Stay away from small tenon saws as they're made for fine work. If you are buying one go for something that's about 40cm or longer with big teeth - shaped like the one on the page before.

Drill bits - a 3mm pilot hole bit, a phillips head driver bit and if you can get one a countersink bit. The countersink bit will cost a few dollars but it will stop your wood from splitting as you drive the screws in (especially if you have jarrah pickets).

A drill

And the only thing better than one drill is 2 drills - it will speed everything up and you won't be changing bits all the time.

If you think you may do more of this you can pick up a two drill kit (impact driver and normal drill) from most hardware stores. If you can go local on the store it that'd be great.

With drills what you are really paying for is the batteries - I'd recommend a two drill kit with two batteries @ 18V and 1.3 amp/hour - if that doesn't make sense it will to the person in the tool shop. Steer very wide and very clear of Ozito drills - I know they're cheaper but the batteries simply do not last (even when you're not using them) and you'll end up buying another set in no time. For a starter kit look for Makita or Bosch or AEG. You won't regret it.

Some screws - 22 would be the minimum and if your wood is 18mm thick go for 32mm screws. If it's thicker or thinner put two bits on top of each other and measure to about half way down the second bit. You'll also need 8 x ~40mm size 8 screws for the jig.

A square - available in all hardware stores. Surprisingly enough a lot of squares you buy aren't square - stay away from ones which slide and have 45 degrees on them - unless they're expensive they're not true. Rule of thumb with set squares is that the heavier it is the better it is.

A clamp - or two. Stay away from the Crafright ones at Bunnings - they're a load of garbage. Old F style clamps are fine if you are borrowing them or if you are going to buy some get the Irwin Quickgrips @ about 300mm long. If you don't have clamps you may have to get someone to give you a hand holding bits occasionally.

Adjustments

So your wood is a different size to mine huh?

Not to worry - the adjustments will just need a little bit of maths.

I decided that I wanted my stool to be about 300mm x 300mm on the top (Part A).

My pickets are 68mm wide so I put 4 of them side by side together and it made 272mm which was close enough to 300mm for me.

From there I then cut Parts A & B to be 272mm long (or 4 pickets wide in simple terms) which would form a square top at 272mm x 272mm.

So if your pickets (or any other wood you have) are say 80mm wide you may choose to use 4 x Part A (which would make a 320mm wide top) and then you'd make Parts A & B 320mm long to form the square.

Next you'll need to adjust the length of part D.

So to figure out the length of Part D you take the length of Part A and minus the thickness of Part B x 2.

Continuing with the previous example of 80mm wide wood lets take 320mm (Length of Part A) and minus the thickness of Part B x 2 (say it's 18mm thick) is $18 \times 2 = 32\text{mm}$.

So Part D is $320\text{mm} - 32\text{mm} = 288\text{mm}$. Makes sense yeah?

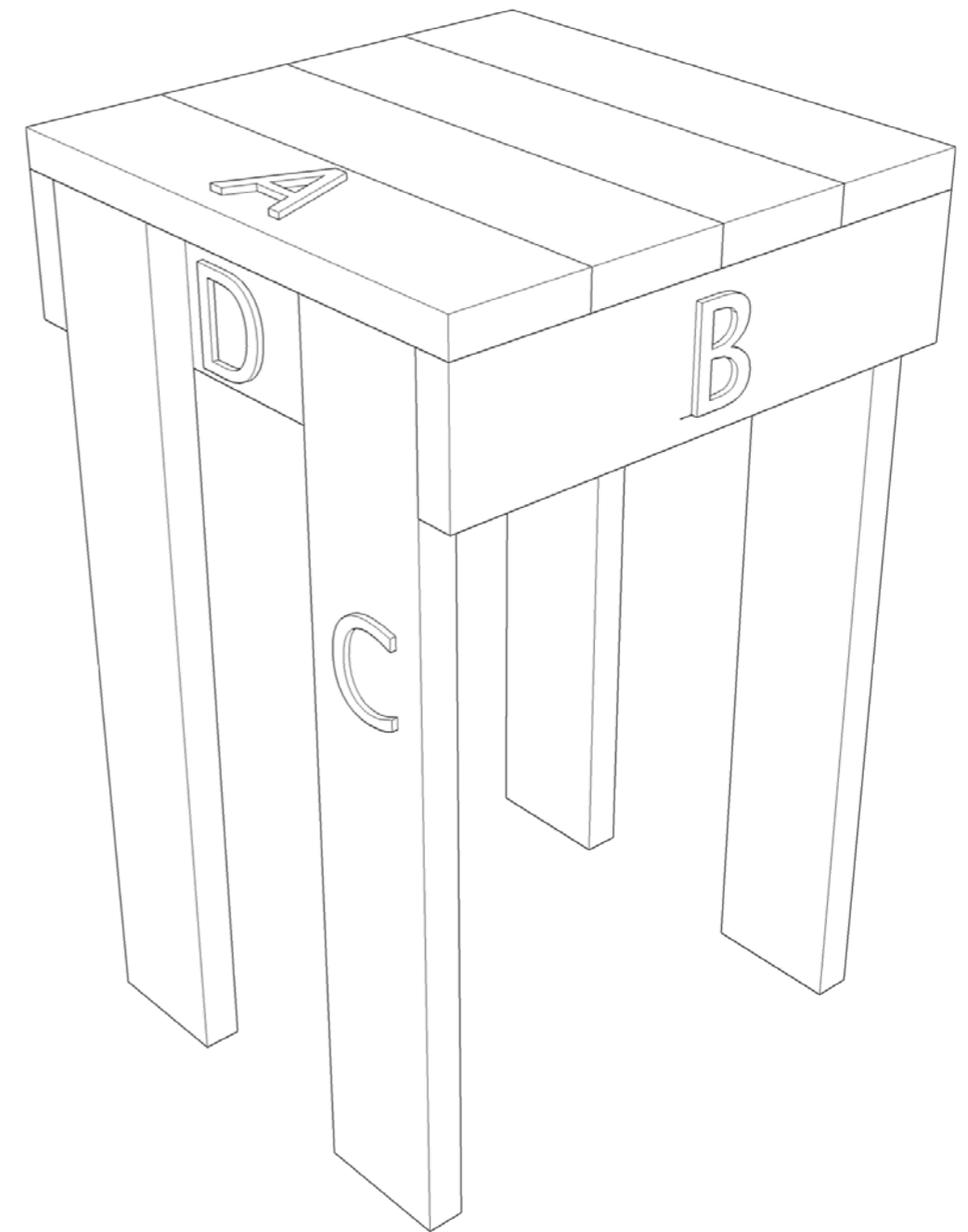

Step 1 - Prep

Now, let's begin...

Removing the nails. Forgive me if this bit seems like I'm teaching you how to suck eggs but it is important to outline every step especially for the novice.

This is the banging step - one of my favourites. Now, some of the most interesting parts of the picket's visually is where the paint meets raw wood. You can simply saw off the nailed bits or if you like the look then bang the nails out.

Set yourself up on a couple of saw horses or a table, hold the wood with one hand and start tapping the pointy end of the nail. If they're already bent you may need to tap them back to being as straight as possible (a pair of pliers can be super handy at this point).

Once the head of the nail is protruding from the other side flip the picket over and use the claw to lever it out with a rolling action. Some nails can be buggers and some will turn into rust dust - just persevere and you'll get the knack.

Banging



Pulling



Tip

If you have 50 pickets then denail them all in one go. You'll thank yourself later when you want to make something and it's ready to work. They'll store better as well by being able to lay flat. Also, get a tetanus booster just in case...

Step 2 - Jig

A jig is something you make in order to make something else in a quicker, safer, more repeatable fashion. This jig will allow you to cut all your bits of wood square and to the right lengths.

For this project the size of the jig pieces isn't important - it is made from scraps. If you have no bits of ply or mdf you may need to get some - a lot of hardware stores will have a "cut shop" where they'll cut wood down to size for a couple of bucks - get a few chopped to the rough size below as it'll allow you to make more and different jigs.

The measurements for the jig below are very much ball park and just a guide - use what is available and is close enough.

IMPORTANT - If you are left handed then reverse the plan - ie make E & F & G line up on the left edge

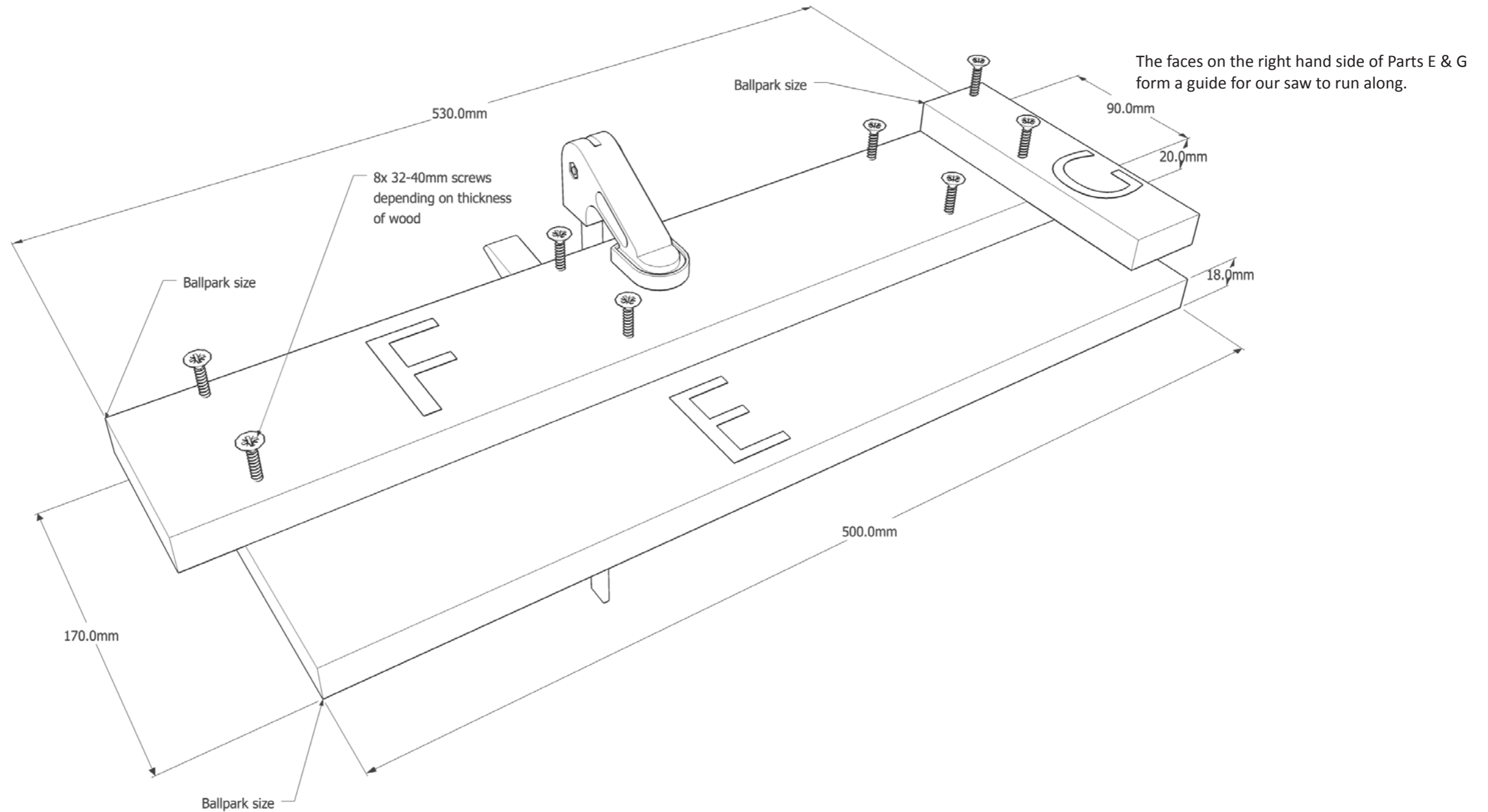

Step 2 - Jig

1. Lay Part F on top of Part E and using a wooden block tap the top and right edges until they sit flush and square.
2. If you are left handed make part F flush to Part E on the left hand side.
3. Clamp the two Parts together, drill pilot holes roughly where indicated in the diagram (Note: the position of the screws on the right hand side) and drive in your screws

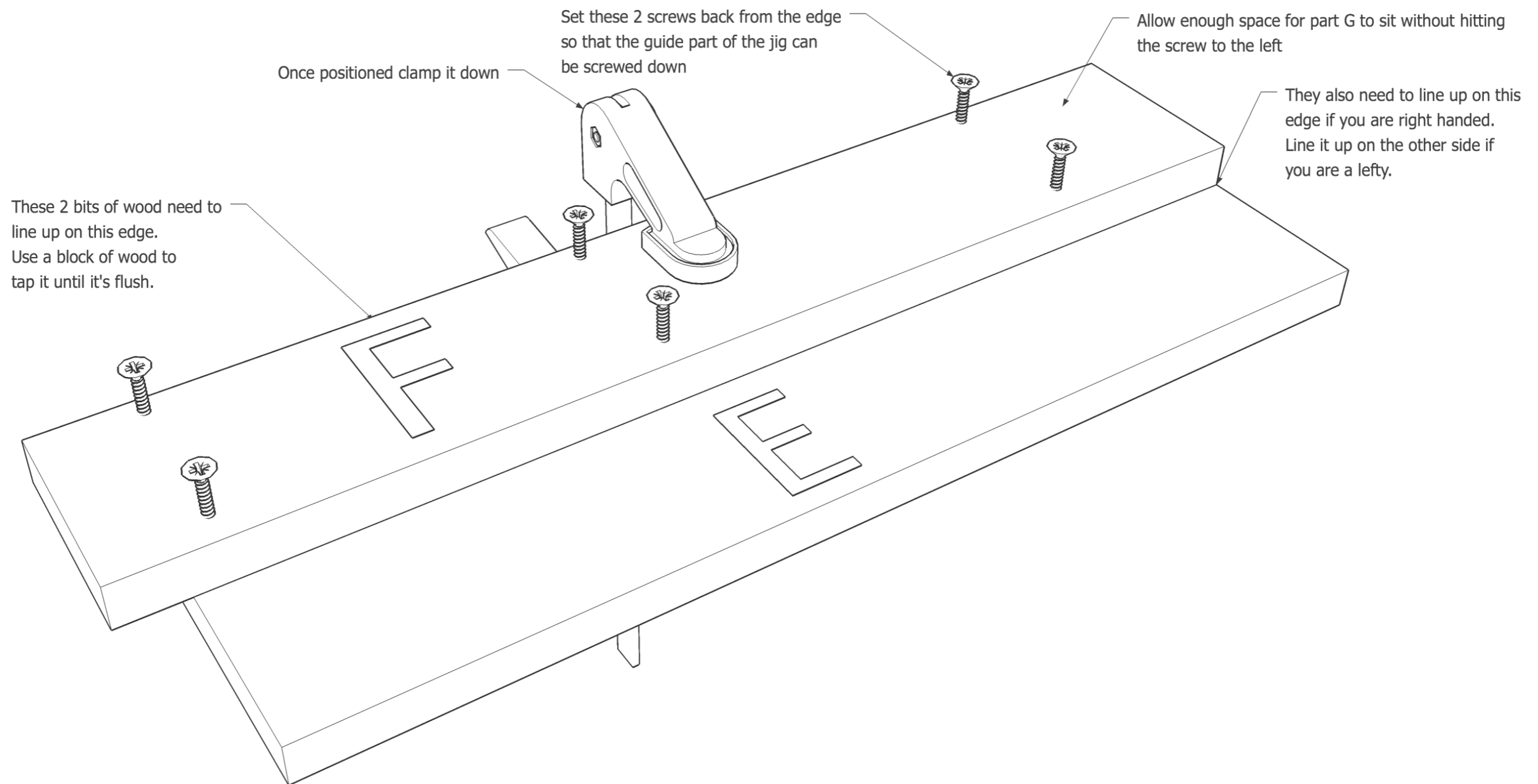

Step 2 - Jig

1. Lay Part G on top of Part F and again tap into squareness - it's very important that the outside edge of G lines up with the outside edge of E. This is what will be used to guide your saw blade and ensure it's cutting at 90 degrees.
2. Drill 2 x 3mm pilot holes and insert screws as shown.

Clamp and attach part G - again use a block of wood to tap until it's square or use a set square or simply measure and draw a line.

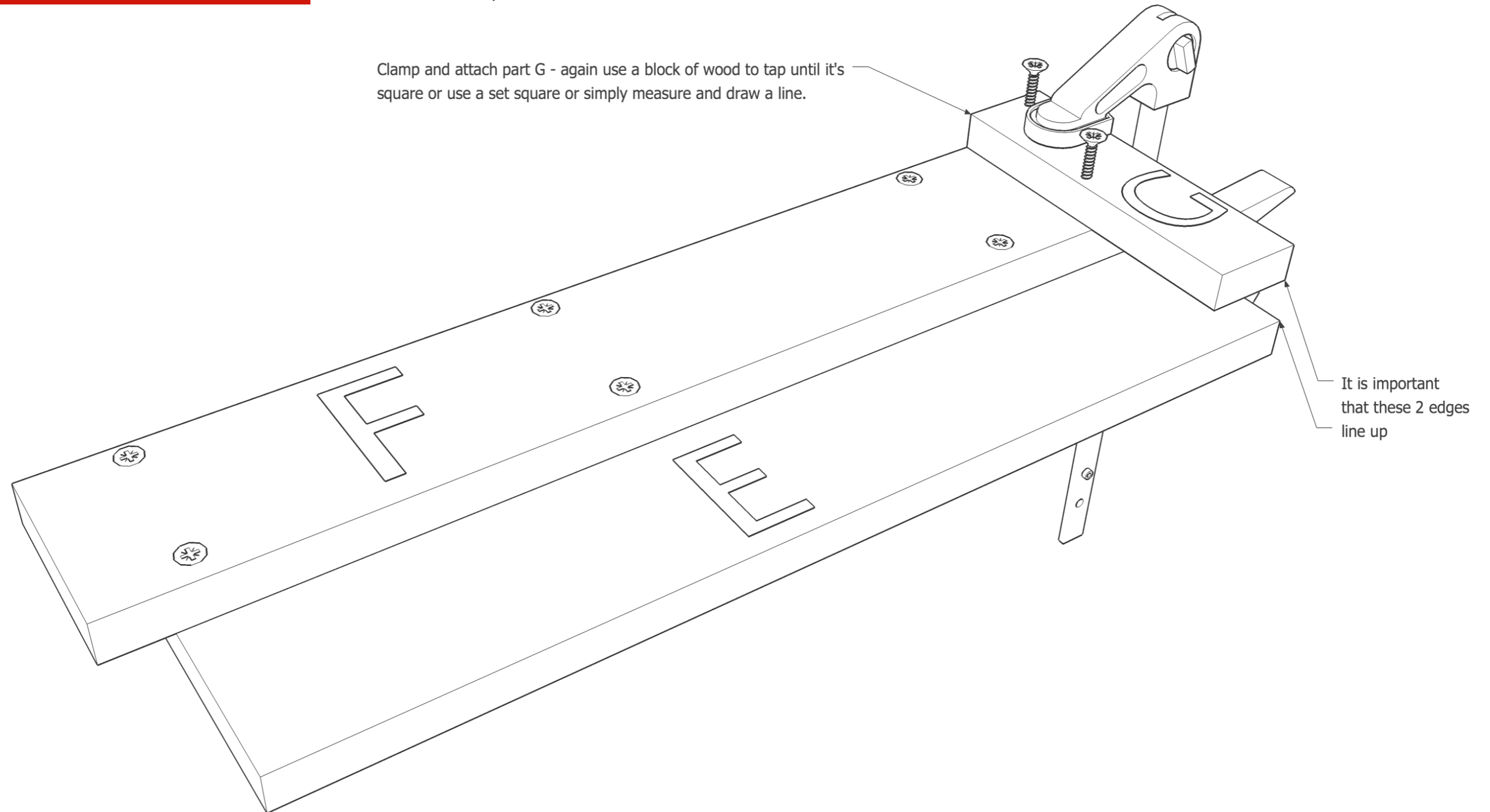

Step 3 - Cutting the Parts

Below is the cut list for the stool. We use the Jig to cut all the parts and we mark the Jig so that we are only measuring once - no matter if we're making one stool or a hundred.

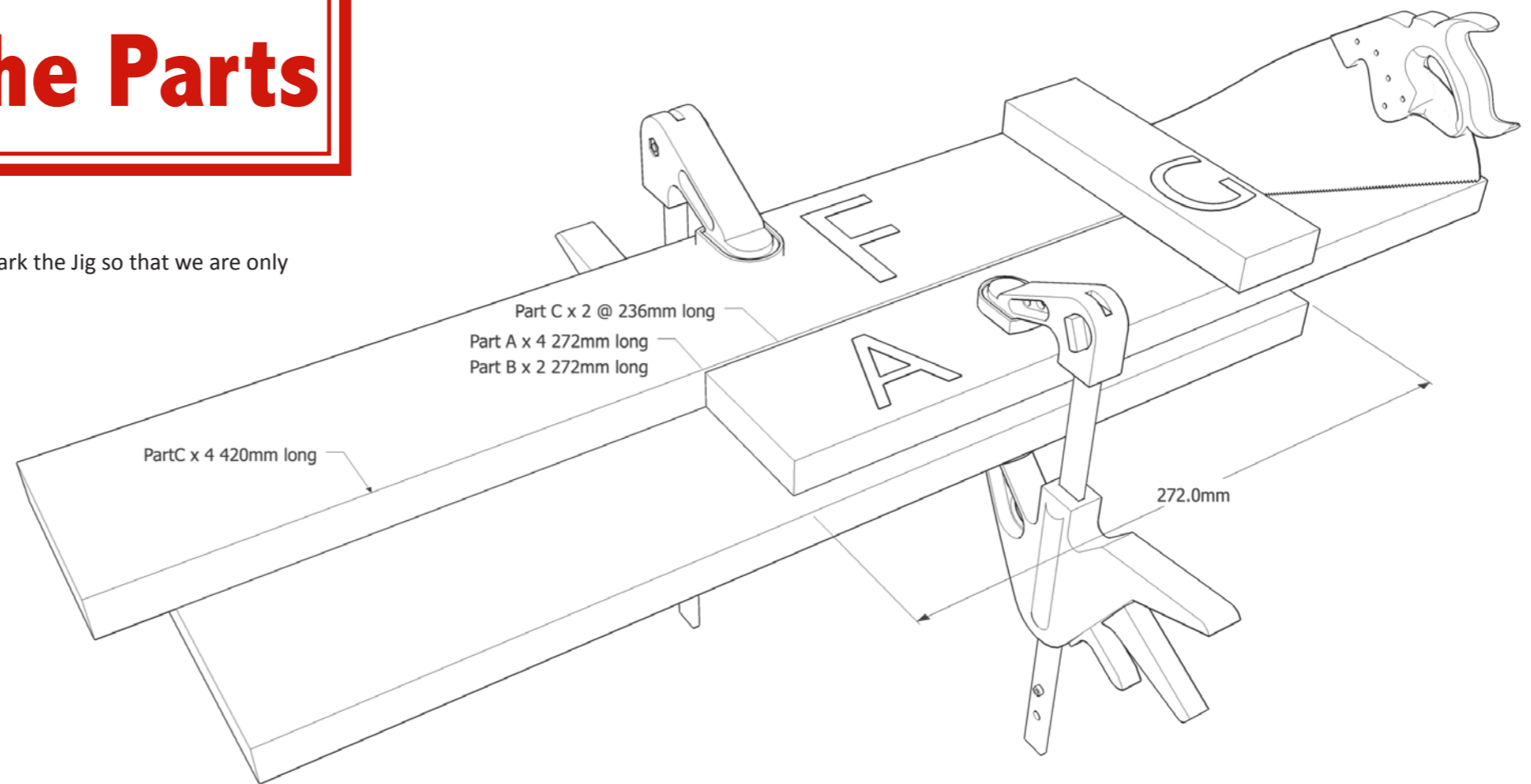
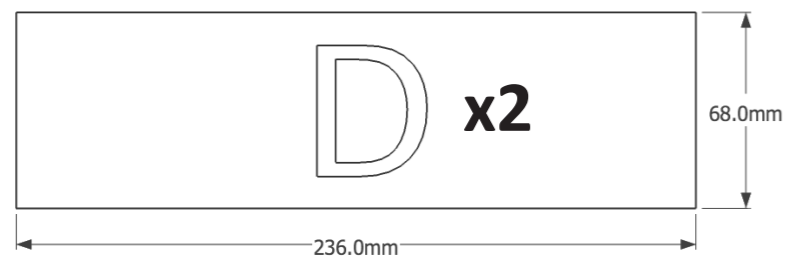
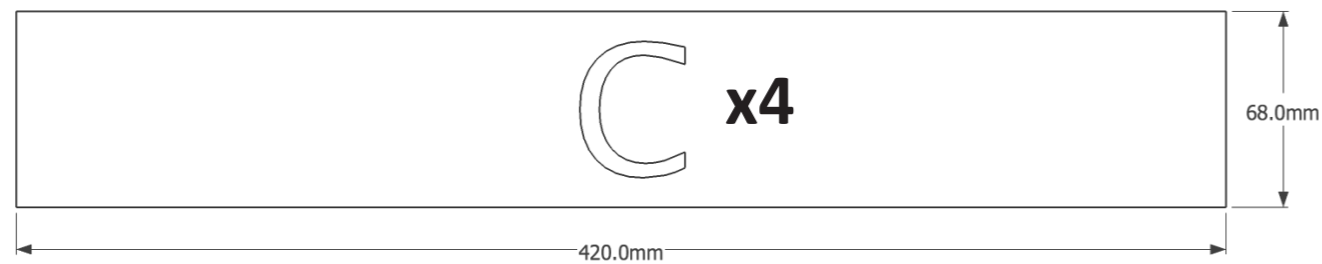
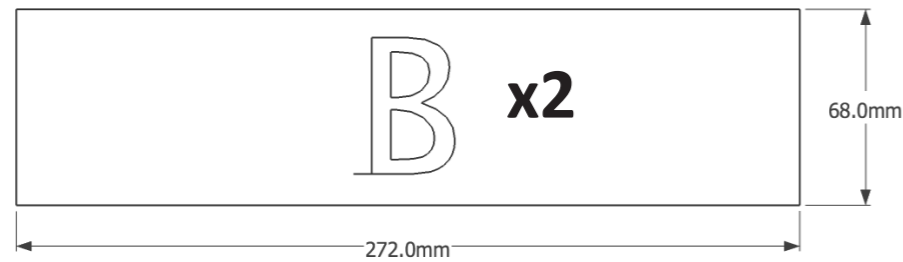
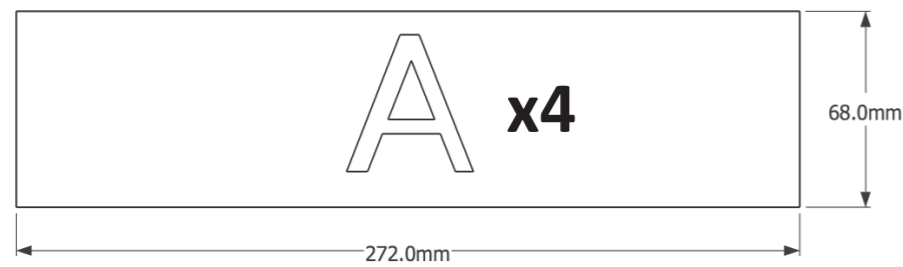

How to Use the Jig

1. Measure 272mm along a picket and use your square to draw a 90 degree line and write on it Part A.
2. Put the picket into the jig as shown and line up your pencil line with the outer edge of Jig Part G - where the saw is in the diagram. Then clamp them together.
3. Use a ruler to rule a line on Part F and write down the name of the piece (Part A in this case), the number of pieces you need (x4 for Part A) and the measurement (272mm for Part A)
4. Now cut 4 x Part A's to length. We do this by placing the saw blade up against the face of Jig Part G & F and allowing it to guide us and keep us straight and true. A saw with larger teeth is best for this kind of cutting as it'll go through the picket in just a few strokes. If you are struggling with it take your time and let the saw do the work - a light touch and a long stroke are the key. After you've cut the part write it's name on it.
5. Repeat steps 1 to 4 for Parts B, C & D and you should end up with a Jig which looks like the one above with markings and measurements on it and a pile of wood to make your stool.
6. Once you've cut them all check that they're the same lengths - if one is a little short or too long then cut another one and put the old one to the side for something else.

Step 4 - Assemble the Stool

The exploded diagram below shows how the stool fits together.

As this is a beginner's plan we won't be using glue as it makes everything a little slippery to work with. What we will be doing is known as dry fitting - which just means sans glue. It gives us the ability to take it apart quite quickly if we need to make adjustments to the design, position/alignment or if we cut a part wrong.

If you are happy with your stool once it is entirely assembled you can then unscrew it and apply glue to give it extra strength.

Step 1

1. Grab 2 x Part C and a Part D. We are going to make the legs.
2. What you need to do is align them as shown in the image below with the corners square (this means at 90 degrees). Now this can be a little frustrating so just lightly clamp one C to one D and then tap it with a block of wood until the faces meet up, check it with your square and then clamp it tighter.
3. Drill two pilot holes into Part C using a 3mm bit about 20mm in from the top and side (refer to diagram for the screw placement - they're set diagonally for better strength)
4. Repeat for the other leg
5. Repeat for the two remaining C's and one D until you have two of the structures shown below.

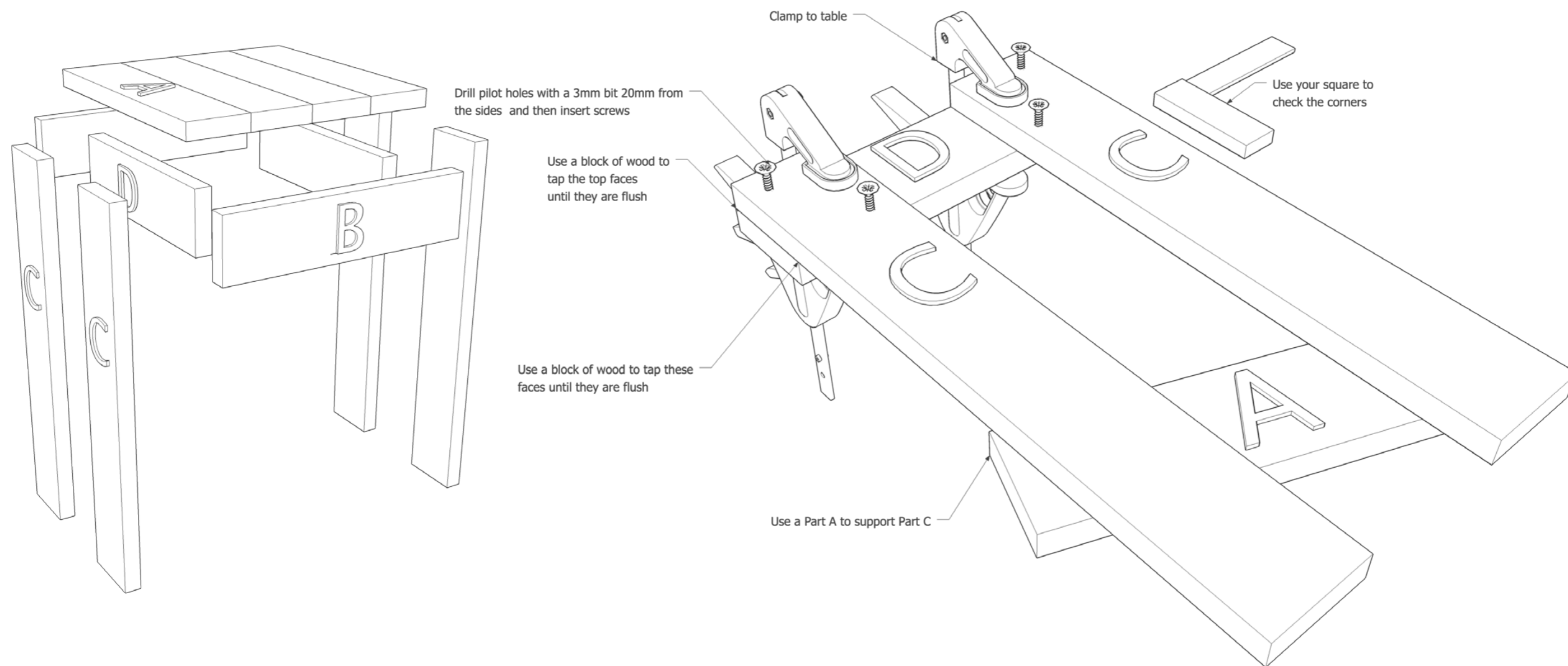

Step 4 - Assemble the Stool

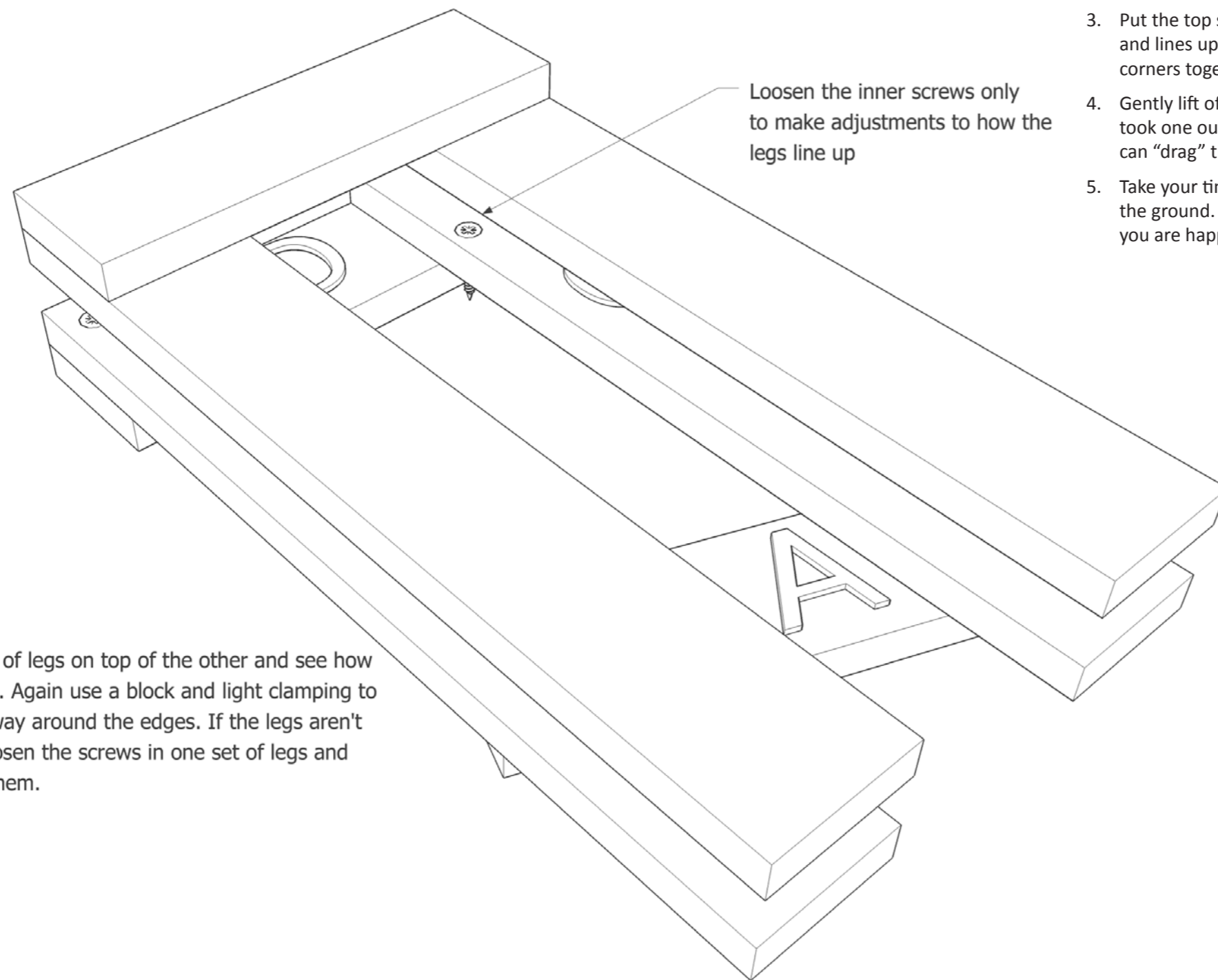

Flip one set of legs on top of the other and see how they line up. Again use a block and light clamping to work your way around the edges. If the legs aren't lining up loosen the screws in one set of legs and reposition them.

Step 2

1. Place both sets of legs face to face as shown in the diagram and see if they line up .
2. If they don't then lift off the top set, and remove one "inner" screw on the bottom set (see diagram) This will allow you to pivot Part C on it's remaining screw and reposition it.
3. Put the top set back on and jiggle around the loose leg until it's in the right position and lines up with the top set. Use your clamps if you have them to help hold the corners together or get your mum to give you a hand.
4. Gently lift off the top set, re clamp the bottom set and put a new screw in where you took one out of before. Sometimes you'll have to drill a new pilot hole as the old hole can "drag" the screw back over and the leg will end up in the wrong position again.
5. Take your time with this step - it's really important for getting your stool to sit flat on the ground. Just work your way round with a block of wood and you're square until you are happy that they line up.

Step 4 - Continued

Step 3

1. Now this step can be a touch fiddly for the first timer so take it easy on yourself if it's slow going.
2. The best way to make it easier is to start by getting your two Part B's and drilling 3mm pilot holes 10mm in from each edge (refer to the Picture 01 for placement).
3. Now stand up your D/C structures on their edge and clamp a Part A as shown in Picture 02. You can also use another Part A down the bottom of the legs to check their spacing. Part A is exactly as wide as the stool will be - use that as your guide.
4. Unless you have very long clamps this part can drive you a little nuts. What you have to do is place Part B as shown, square it up using a block of wood and set square, and then drill through the pilot holes you put in Part B and into Part C. If you are struggling to hold it and drill it at the same time then it might be a case of getting someone to give you a hand to hold it in position.
5. Once you've got one side on flip the whole structure and attach the other Part B on the other side.
6. Check for squareness as you work and once both Part B's are attached stand it up on it's feet - if it's a little too rocky then remove one screw, jiggle it around 'til it's flush and pop a screw back in.

Picture 02

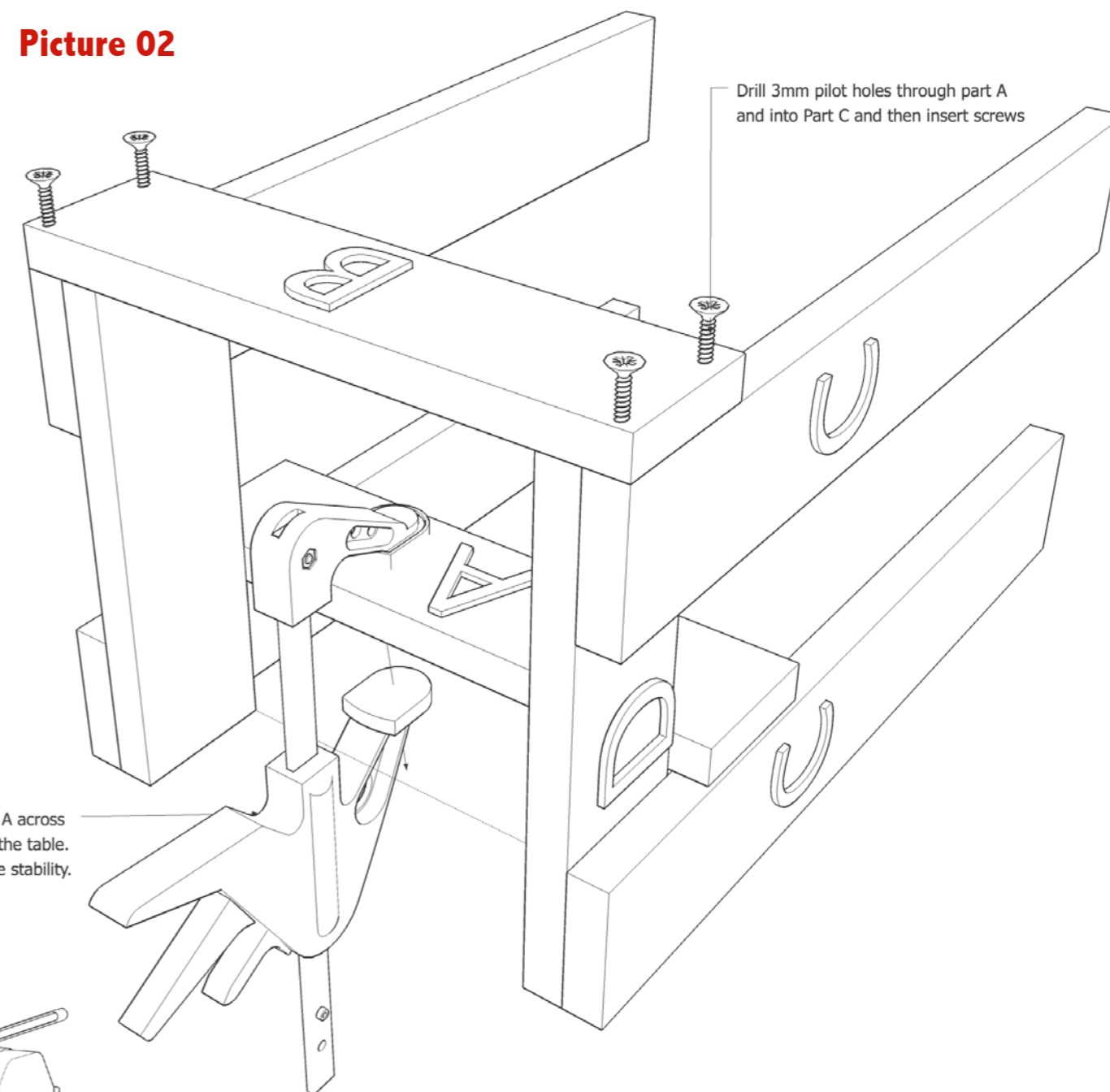

Picture 01

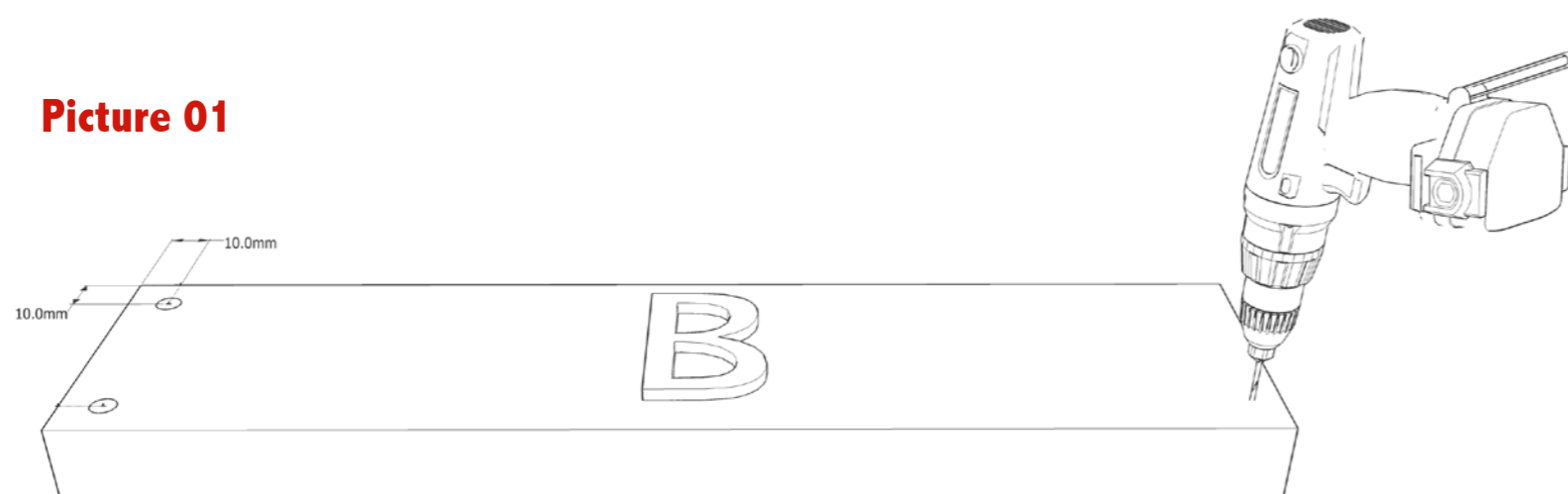

Step 4 - Continued

Step 4

1. Take a Part A and use your wooden block to position it as shown and then clamp it to Part D.
2. Drill a 3mm pilot hole 10mm in from each corner and then insert screws
3. Repeat for the other Part A slats from left to right
4. Sit down and enjoy yourself a well earned Frosty Fruit.

Please let me know how you went and if you ran into any problems/failings with the plan by sending me an email to workshop@agoodlookingman.com.au

If you wanted to send me a photo as well I'd really appreciate it.

If you're all up on social media you can follow me on Facebook by clicking [here](#) and if you're a fan of the hashtag on Instagram and Twitter a #agoodlookingman would be much appreciated.

The website www.agoodlookingman.com.au will be updated pretty regularly and there will be more plans to come - throw a bookmark on it in your browser.

There is also a registration section for future workshops so get on that list and stay in the loop.

Many thanks

Andy

A Good Looking Man

